

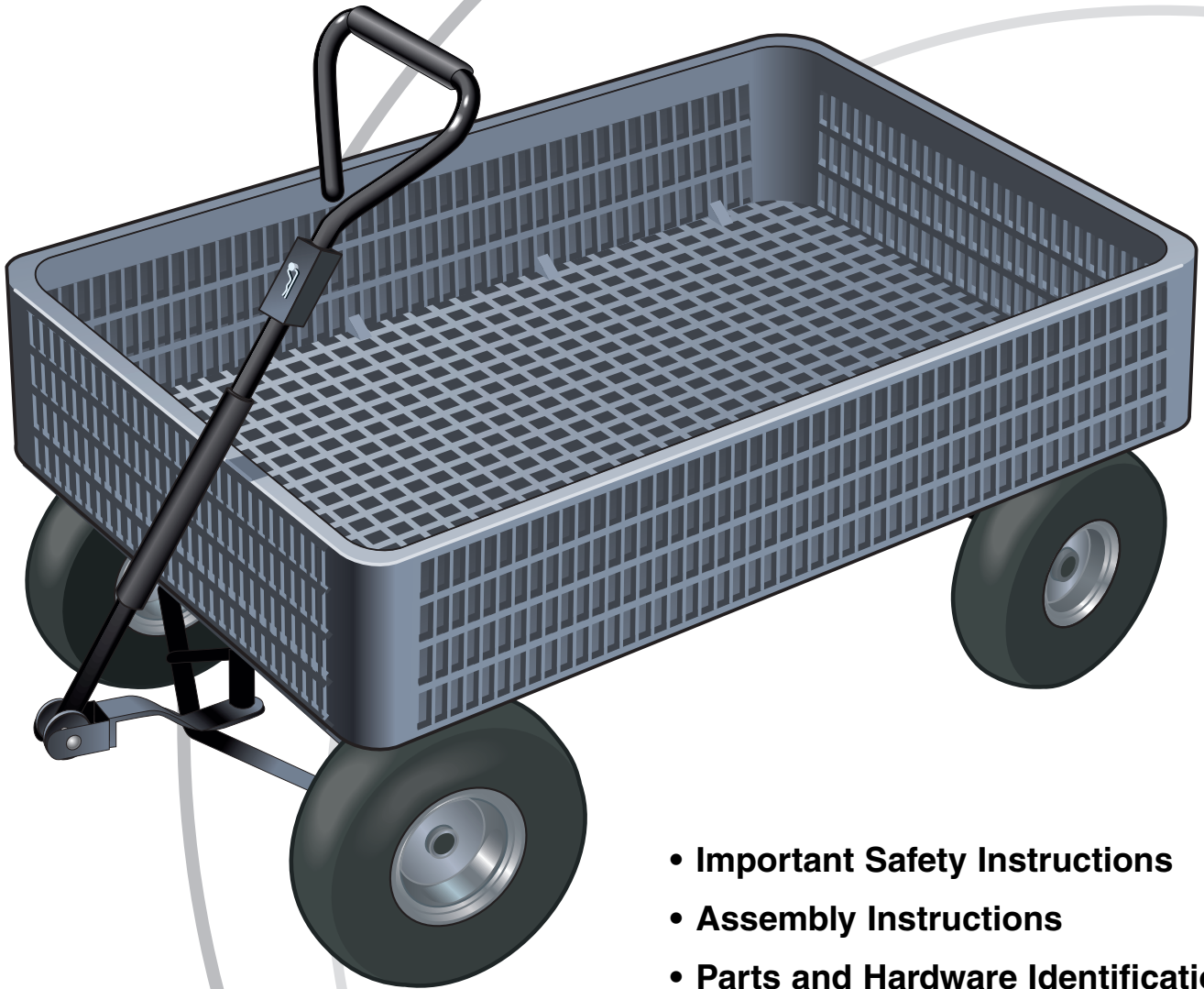

OWNER'S MANUAL

Model MH1040A



- Important Safety Instructions
- Assembly Instructions
- Parts and Hardware Identification

Plastic Crate Cart

CAUTION:

Read, understand and follow ALL instructions before using this product

Tricam
7677 Equitable Drive
Minneapolis, MN 55344
800-304-1316

IMPORTANT SAFETY INSTRUCTIONS

1. **READ ALL INSTRUCTIONS CAREFULLY BEFORE USE.** If you do not understand these instructions, need clarification or further explanation, please call our toll free answer line for assistance at **1-800-304-1316** Monday through Friday 8:00 a.m. until 5:00 p.m. CST.
2. Do not load Plastic Crate Cart with more than 1200 lbs. (544 kg)
3. Do not allow children to use the cart unsupervised. This Plastic Crate Cart is not a toy.
4. Always distribute payload evenly over surface of Crate.
5. If any parts become damaged, broken or misplaced do not use the Cart until replacement parts can be obtained.
6. Do not operate or use on objects that can cause damage to the pneumatic tires or tubes.
Do not inflate tires more than 30 psi.
7. **SAVE THESE INSTRUCTIONS.**

ASSEMBLY INSTRUCTIONS

Your Plastic Crate Cart requires assembly. Account for all parts and hardware before beginning assembly. If any parts are missing, damaged or if you have questions or need additional instructions **DO NOT RETURN THIS PRODUCT TO THE RETAILER**, call the manufacturer at **1-800-304-1316**.

Tools required for assembly: Medium size slot screwdriver, 6, 8, and 12mm open end wrench and /or two medium adjustable wrenches.

Refer to the exploded drawing and the parts list on the following pages during assembly.

- STEP 1** Turn the cart BED upside down. Use the cardboard from the carton to keep from scratching or damaging the finish.
- STEP 2** Assemble the REAR SUPPORT ASSEMBLY to the frame support using 4 - 6 X16mm Frame Support Bolts and 6mm nuts. Tighten all nuts securely.
- STEP 3** **There are four shoulder bolts - three short and one long. Be sure to use the long shoulder bolt (8 x 17mm) in the front center location of the steering mechanism.** Assemble the FRONT SUPPORT ASSEMBLY completely before attaching the completed assembly to the Frame Support.
- A. Attach the Steering Link Connector to the two axle guides using 2 - 8 x 15mm Steering Assembly Shoulder Bolts (short), 6mm Washers and 6mm Nuts. **NOTE:** Place the Steering Link Connector on top of the axle guides.
 - B. Secure upper Yoke to the upper Front Axle Support Frame using washer and cotter pin.
 - C. Attach lower Yoke and Center Front Axle Brace to the assembly as shown. Use 1 - 8 x 17mm Steering Assembly Shoulder Bolt (long), 6mm Washer and 6mm Nut.
 - D. Attach the Steering Link Connector using 1 - 8 x 15mm Steering Assembly Shoulder Bolt (short), 6mm Washer and 6mm Nut.
 - E. Assemble the completed Front Support Assembly to the Frame using 4-Frame Support Bolts and nuts. Secure Center Front Axle Brace to the Frame Support using 2 - 8mm Bolts and nuts
- STEP 4** Attach the frame support to the crate using the 8mm bolts, washers, and lock nuts.
- STEP 5** Install the WHEELS in the following order.
- A. Place the Wheel Spacer bushing onto the axle.
 - B. Place the Wheel onto the axle with the valve stem facing out.
 - C. Use the 12mm washer and then the 12mm Nut to secure the wheel. Tighten Securely.
- STEP 6** Turn the cart upright onto its wheels. Attach the Tractor Pull Handle Yoke Washers and the Plastic Coupling using the 8 x 60mm pull handle bolt, 8mm washer and nut. Attach either the Pull Handle or the Trailer Hitch using the handle pin and clevis pin provided.

PARTS AND HARDWARE IDENTIFICATION

MAIN FRAME PARTS

- 1 Bed - (1)
- 2 13" Wheels - (4)

REAR SUPPORT ASSEMBLY

- 3 Rear Axle Support - (1)
- 4 Frame Support - (1)

FRONT SUPPORT ASSEMBLY

- 5 Front Axle Support - (1)
- 6 Center Front Axle Brace - (1)
- 7 Yoke - (1)
- 8 Steering Link Connector - (1)
- 9 Plastic Coupling - (1)
- 10a Trailer Hitch - (1)
- 10b Pull Handle - (1)
- 11 Tractor Pull Handle - (1)

ASSEMBLY HARDWARE

- 12 Handle Clevis Pin - (2)
- 13 Clevis Pin - (2)
- 14 Washer 8mm - (1)
- 15 Nuts w/Lock Inserts 8mm - (9)
- 16 Wheel Spacer Bushings - (4)
- 17 Wheel Nuts 12mm - (4)
- 18 Wheel Lock Washers 12mm - (4)
- 19 Center Front Axle Brace Bolts
8 x 20mm - (2) use with #15
- 20 Pull Handle Bolt 8 x 60mm - (1)
use with #14 & #15
- 21 Short Steering Assembly Shoulder Bolt
8 x 15mm - (3) use with #24 & #25
- 22 Long Steering Assembly Shoulder Bolt
8 x 17mm - (1) use with #24 & #25
- 23 Yoke & Cart Bed Washers
8 x 25mm OD- (8)
- 24 Washers 6mm - (4)
- 25 Nuts w/Lock Inserts 6mm - (12)
- 26 Cart Bed Bolts 8 x 45mm - (6)
- 27 Frame Support Bolts 6 x 16mm - (8)
- 28 Front Axle Cotter pin (1)
- 29 Front Axle Washer 10mm - (1)

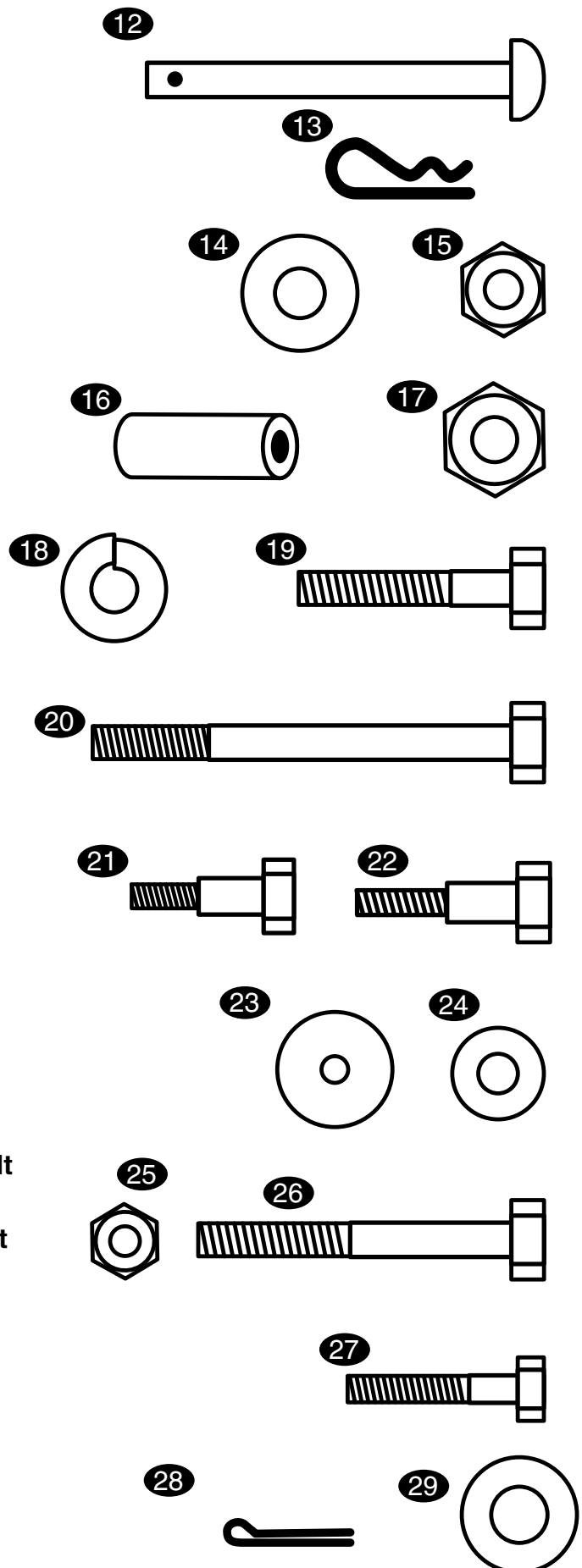

EXPLODED DRAWING FOR ASSEMBLY

