



OWNER'S MANUAL

Model MH1210



- **Warning: Not for recreational use - persons should never ride in cart**
- **Warning: Do not tow cart in excess of 15 mph - never tow behind car or truck**
- **Warning: Not for high speed or highway use**

Monster Wagon

CAUTION:

Read, understand and follow ALL instructions before using this product

**Tricam International
7677 Equitable Drive
Minneapolis, MN 55344
800-304-1316**

IMPORTANT SAFETY INSTRUCTIONS

1. **READ ALL INSTRUCTIONS CAREFULLY BEFORE USE.** If you do not understand these instructions, need clarification or further explanation, please call our toll free answer line for assistance at **1-800-304-1316** Monday through Friday 8:00 a.m. until 5:00 p.m. CST.
2. Do not load wagon with more than 2000 lbs. (908 kg)
3. Do not allow children to use the wagon unsupervised. This wagon is not a toy.
4. Always distribute payload evenly over surface of bed.
5. Do not load any items on top of the fence. Lower fence when objects are to be loaded onto the wagon.
6. If any parts become damaged, broken or misplaced, do not use the wagon until replacement parts can be obtained.
7. Do not operate or use on objects that can cause damage to the pneumatic tires or tubes.
Do not inflate tires more than 35 psi.
8. **SAVE THESE INSTRUCTIONS.**

ASSEMBLY INSTRUCTIONS

Your Monster Wagon requires assembly. Account for all parts and hardware before beginning assembly. If any parts are missing, damaged or if you have questions or need additional instructions **DO NOT RETURN THIS PRODUCT TO THE RETAILER**, call the manufacturer at **1-800-304-1316**.

Tools required for assembly: Metric Socket Set, Wrenches and pliers.

STEP 1

Lay the base panels (1A) & (1B) upside down on the ground making sure the holes are aligned. It is helpful to use a screwdriver to align the holes properly.

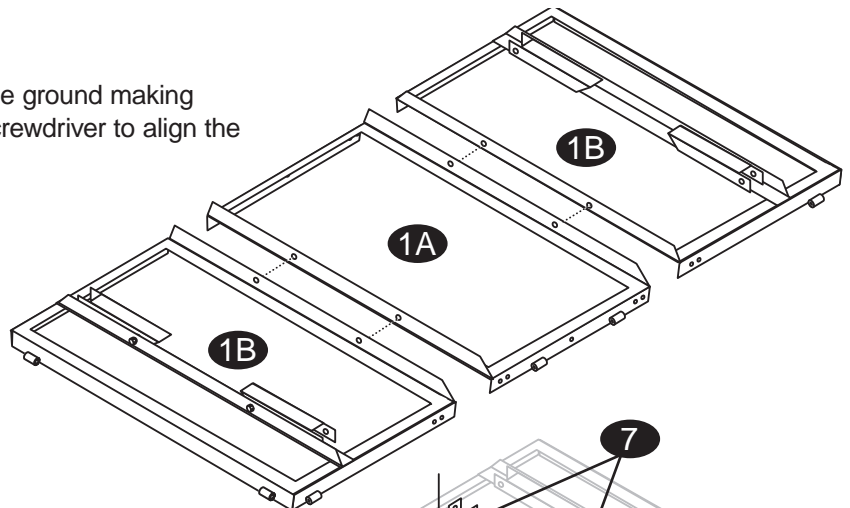

STEP 2

Note the hole location of the four straight support brackets (7) that are wrapped to the frame. Remove these brackets from the frame and assemble to the panels using four 10 x 35mm bolts (16), washers (26) and lock nuts (22). These four brackets will connect the three base panels together. Make sure to only finger tighten the lock nuts. (See Diagram)

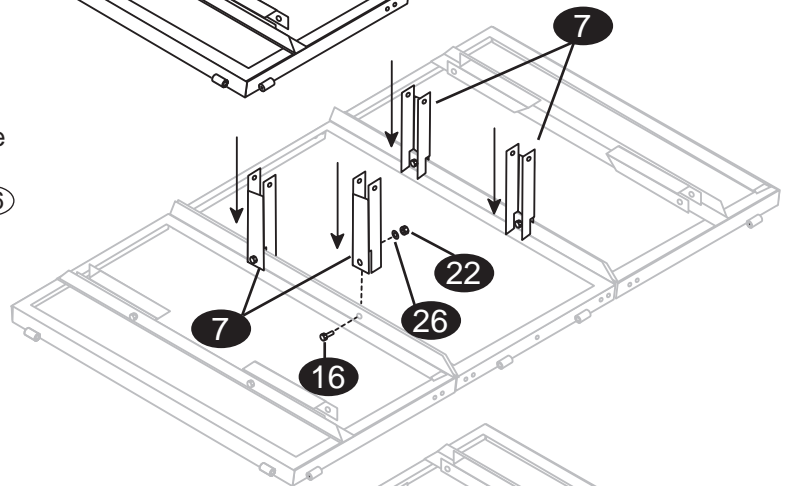

STEP 3

The angled support brackets (8) & (9) have been bolted to the base panels (1B) at the factory. Pivot two of these brackets so they are at about a 75-degree angle pointing towards the outside edge of the base panels. (See Diagram)

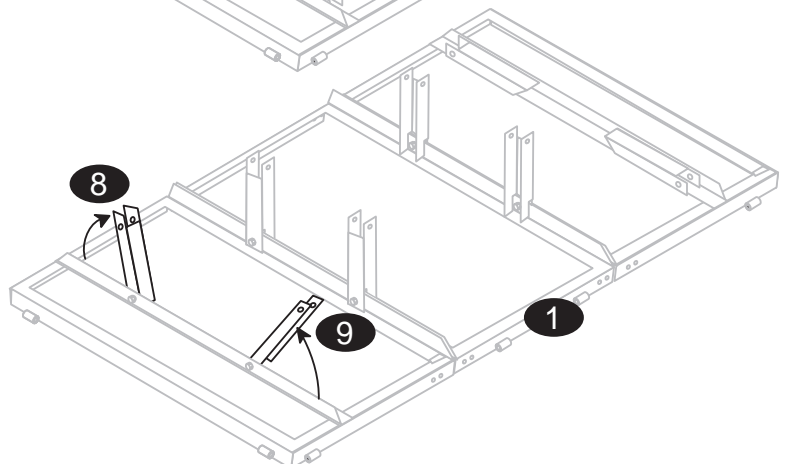

STEP 4

To install the front axle assembly (13) to the base panels, place the entire front axle assembly on top of the two angled support brackets that have been pivoted and two of the straight support brackets. Install four 10 x 60mm bolts (17), washers (26), and lock nuts (22). The tie rods on the axle should be on the side that will be closest to the ground when upright.

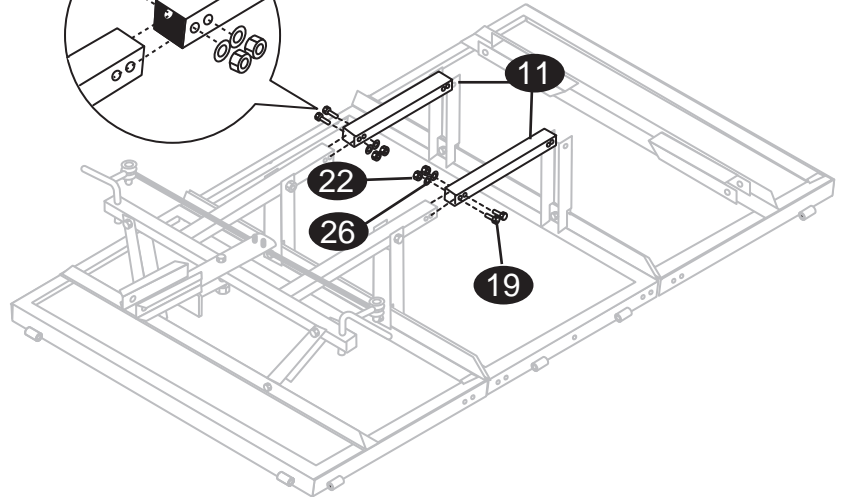
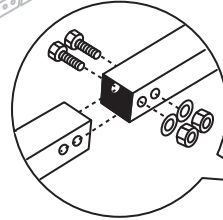
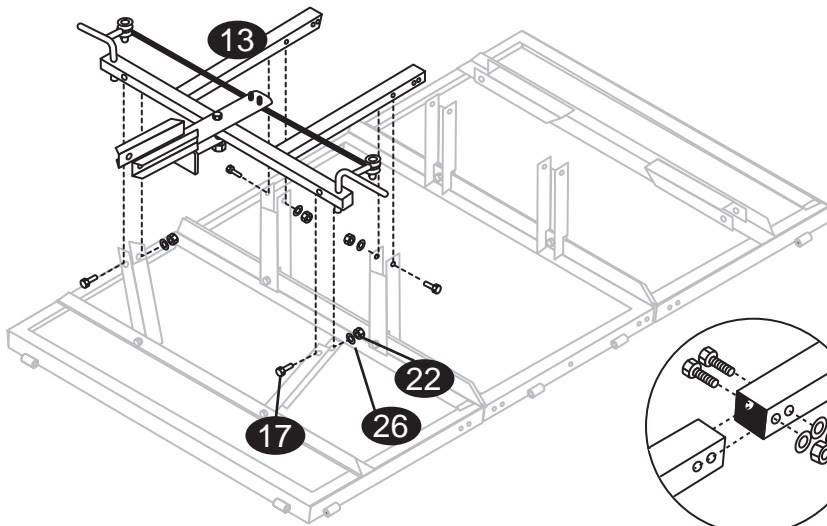

STEP 5

Insert frame tube connectors (11) into front axle frame and secure with four 10 x 50mm bolts (19), washers (26), and lock nuts (22). (See Diagram)

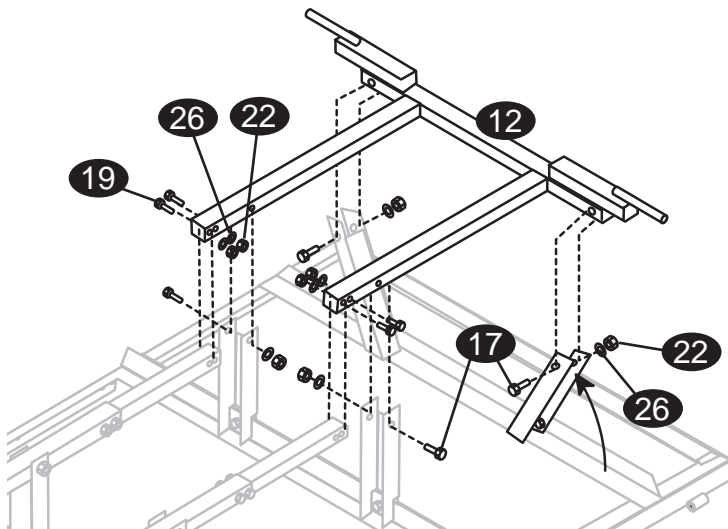

STEP 6

Insert the rear axle assembly (12) onto the frame tube connectors. Make sure the assembly is resting properly into the two remaining straight support brackets. Insert two 10 x 60mm bolts (17) through straight support brackets and add washers (26), and lock nuts (22). Install the last four 10 x 50mm bolts (19), washers (26), and lock nuts (22) to fasten the rear axle assembly to the frame tube connectors. Pivot the angled support brackets from the rear base panel so they align properly to fit the rear axle assembly. Insert two 10 x 60mm bolts (17), washers (26), and lock nuts (22). Finger tighten only.

To make the next steps less difficult, it is recommended that the unit be turned over.

STEP 7

Assemble the four side panels (2A) & (2B) using the 80mm pins (29) and clips (31). Make sure the notches for the locking mechanism are in the corners of the wagon. The flat side of each panel should be on the outside.

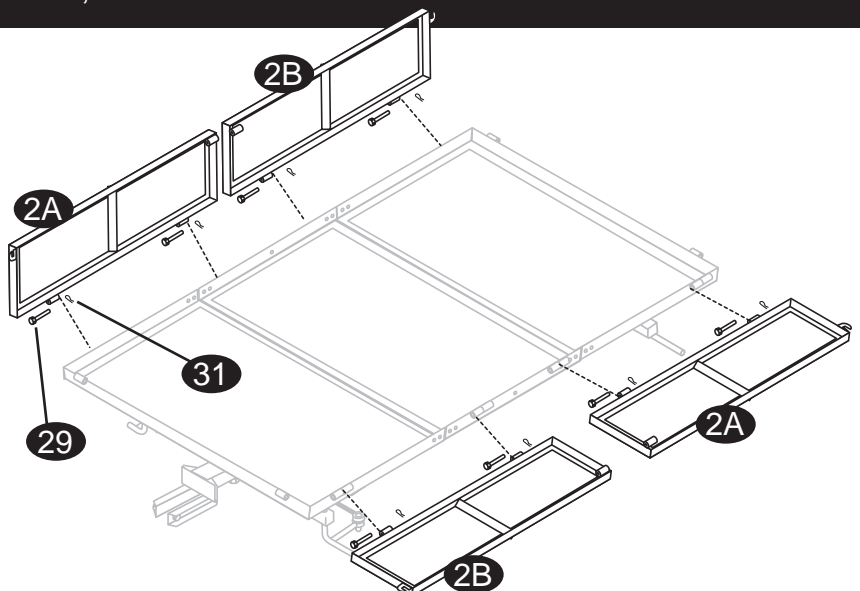

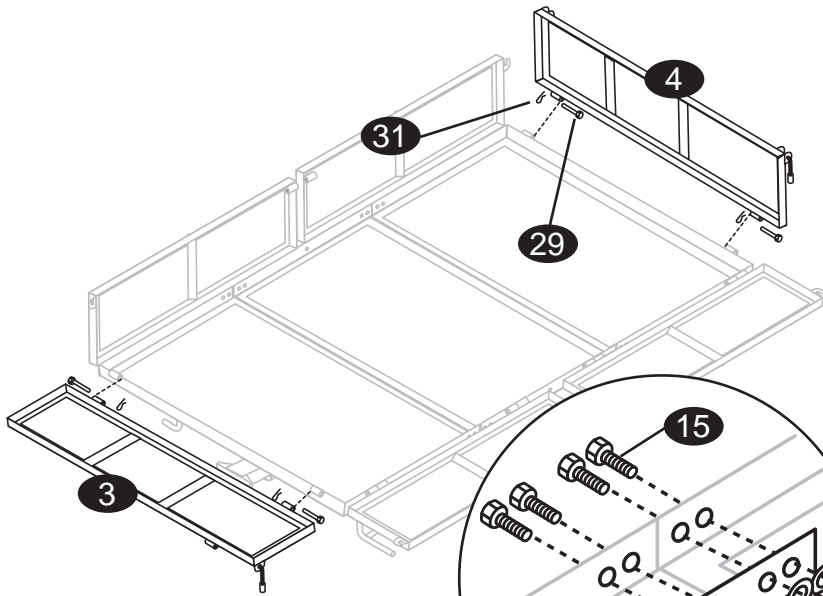

STEP 8

Assemble the front (3) and rear panels (4) using the 80mm pins (29) and clips (31). Again, the flat side of each panel should be on the outside.

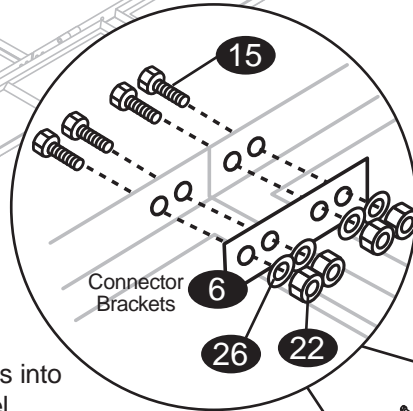

STEP 9

Before engaging the locking mechanism to lock the side panels into place with the front and rear panel, assemble the four connector brackets (6) to the base panels using the sixteen 10 x 20mm bolts (15), washers (26), and lock nuts (22). Use a screwdriver if necessary to align holes properly.

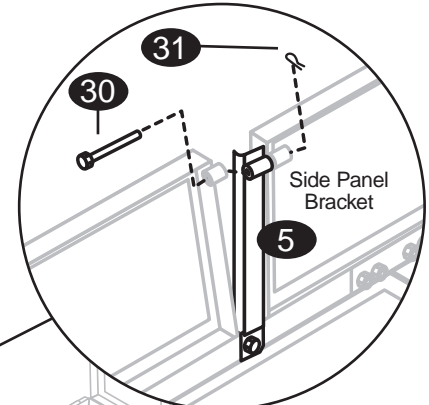

STEP 10

Attach the side panel brackets (5) to the base panels using the two 8 x 20mm bolts (18), washers (25), and lock nuts (23). The circular tube for the pin should face inward. Insert one 100mm pin (30) and clip (31) in each side to secure the brackets to the side panels.

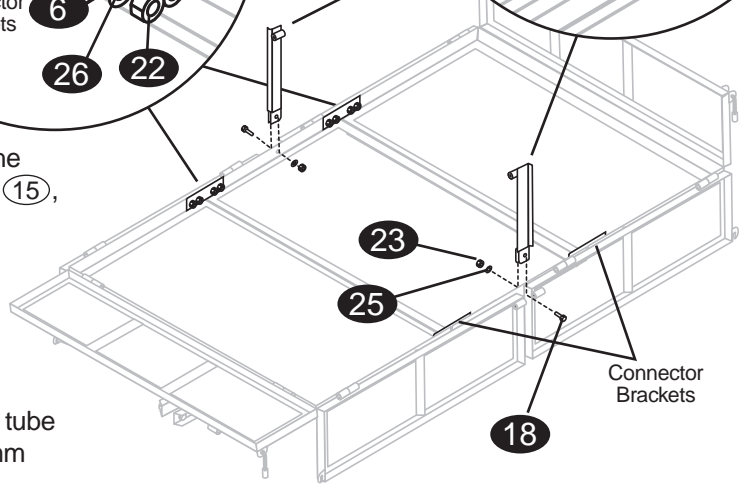

STEP 11

Test the locking mechanism on the front and rear panels. To make any adjustments, tighten or loosen the nuts on the locking mechanism. Lock all panels into place.

To make the next steps less difficult, it is again recommended that the unit be turned over.

STEP 12

Prior to attaching the wheels and the handle, firmly tighten all bolts and lock nuts from prior steps.

STEP 13

Slide the four wheels (10) onto each axle. Place a 20mm washer (28) on the outside of each tire and slide a large cotter pin (33) into the hole in the axle. Be sure to bend one side of the cotter pin for a secure attachment.

STEP 14

Install the tractor pull handle (14) into the front part of the yoke using the 12 x 60mm bolt (20), washer (27), and lock nut (24). The bolt should be tight, but the handle should be able to move up and down freely.

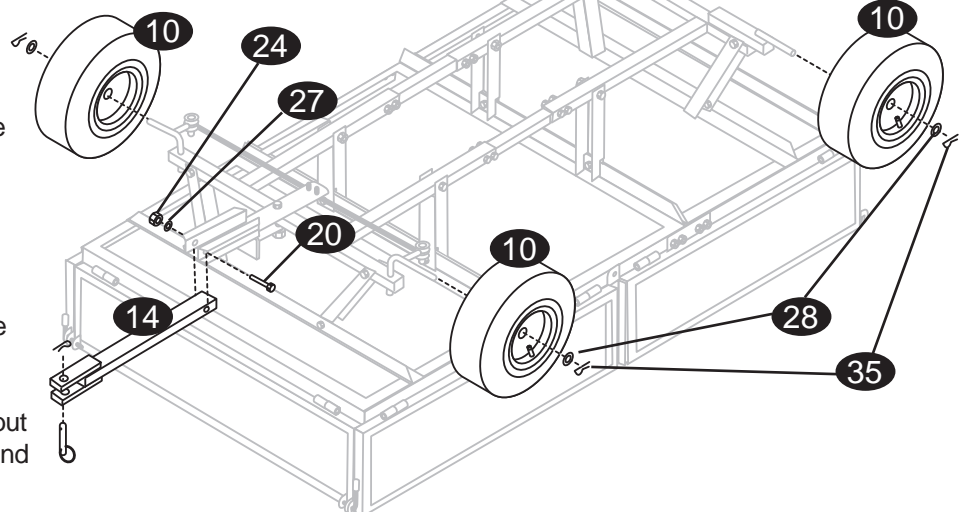
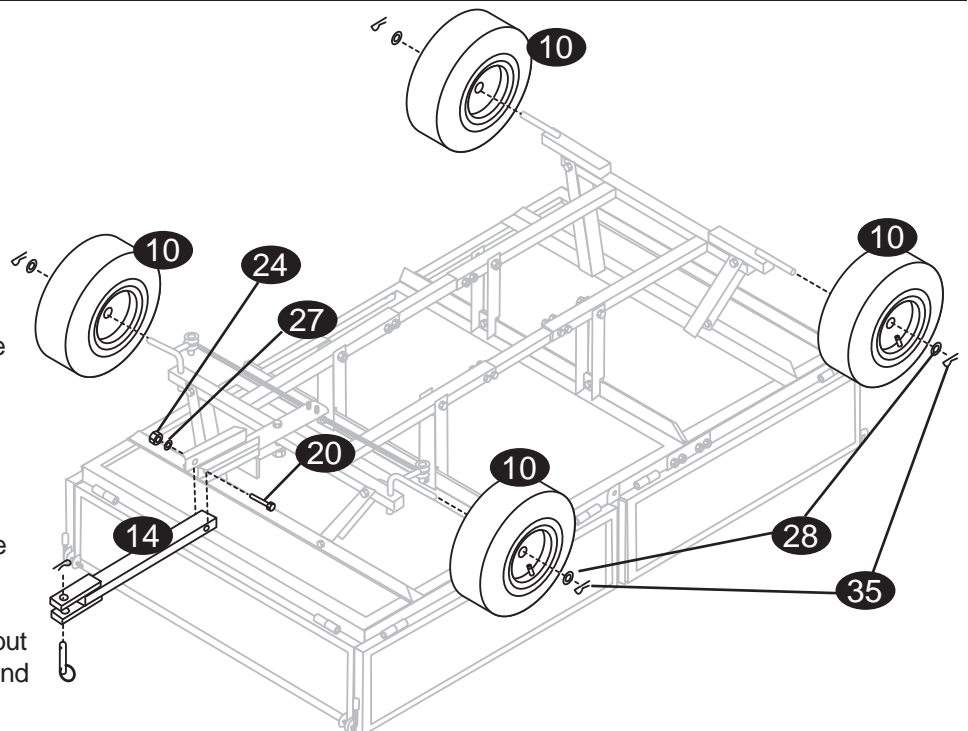

PARTS AND HARDWARE IDENTIFICATION

MAIN FRAME PARTS

- 1A Base Panel (Center) – (1)
 - 1B Base Panel (Front & Back) – (2)
 - 2A Side Panels – (2)
 - 2B Side Panels – (2)
 - 3 Front Panel – (1)
 - 4 Rear Panel – (1)
 - 5 Side Panel Brackets – (2)
 - 6 Connector Brackets – (4)
 - 7 Straight Support Brackets(Center) – (4)
 - 8 Angled Support Brackets (Right) – (2)
 - 9 Angled Support Brackets (Left) – (2)
 - 10 16” Pneumatic Tires W/Rims – (4)
-

LOWER FRAME ASSEMBLY

- 11 Frame Tube Connectors – (2)
 - 12 Rear Axle Assembly – (1)
 - 13 Front Axle Assembly – (1)
-

HANDLE ASSEMBLY

- 14 Tractor Pull Handle – (1)
-

ASSEMBLY HARDWARE

- 15 Bolts 10 x 20mm – (20) 16 for connector brackets, 4 pre-assembled to angled support brackets
- 16 Bolts 10 x 35mm – (4) for straight support brackets
- 17 Bolts 10 x 60mm – (8) for straight and angled support brackets
- 18 Bolts 8 x 20mm – (2) for side panel brackets
- 19 Bolts 10 x 50mm – (8) for installing tube connectors to front and rear axle frame
- 20 Bolts 12 x 60mm – (1) for installing pull handle
- 21 Bolts 12 x 80mm – (1) pre-assembled to front axle assembly
- 22 Lock Nuts 10mm – (40)
- 23 Lock Nuts 8mm – (6) 4 pre-assembled lock handles, 2 for side panel brackets
- 24 Lock Nuts 12mm – (2) 1 for installing tractor pull handle. 1 pre-assembled to front axle assembly
- 25 Washers 8mm – (6) 2 for side panel brackets, 4 pre-assembled to lock handles
- 26 Washers 10mm – (40)
- 27 Washers 12mm – (2) 1 for installing pull handle, 1 pre-assembled to front axle assembly
- 28 Washers 20mm – (6) 4 used on wheels, 2 pre-assembled to front axles
- 29 Pins 80mm – (12) for attaching side panels to base panels
- 30 Pins 100mm – (2) for attaching side panels to side panel brackets
- 31 Clips – (14) for use with 80mm & 100mm pins
- 32 Small Cotter Pins – (2) pre-assembled on front axle assembly
- 33 Large Cotter Pins – (6) 4 for retaining wheels, 2 pre-assembled to front axle assembly
- 34 Small Clevis Pins – (2) pre-assembled on front axle assembly
- 35 Large Clevis Pin – (1) pre-assembled on tractor pull handle
- 36 Clevis Clip – (1) pre-assembled on tractor pull handle
- 37 Lock Handles 8mm – (4) pre-assembled on front and rear panels

EXPLODED DRAWING FOR ASSEMBLY

