



# Pull-Behind Steel Utility Cart



## Owners Manual Model YRD1245-14

- Important Safety Instructions
- Assembly Instructions
- Parts and Hardware Identification

CAUTION: Read, understand and follow ALL instructions before using this product.

WARNING: Not for recreational use. Persons should never ride in the cart.

Questions, problems, or missing parts? Before returning to your retailer, visit us online at [www.tricam.com](http://www.tricam.com) and complete the replacement parts submission form or call our customer service department at 1-800-867-6763, 9 a.m. - 4 p.m., CST, Monday-Friday.

For product inquiries:  
Tricam  
7677 Equitable Drive  
Eden Prairie, MN 55344  
1-800-867-6763  
[www.tricam.com](http://www.tricam.com)

## Exploded Drawing for Assembly

### Parts List

- A. Bed (1)
- B. Side Panels (2)
- C. Front Panel (1)
- D. Back Panel (1)
- E. 10in (25.4cm) Wheels (4)
- F. Front Axle Sub-Assembly (1)
- G. Yoke (1)
- H. Front Strut (1)
- I. Front Axle Connection Bar (1)
- J. Rear Axle Sub-Assembly (1)
- K. Rear Struts (2)
- L. Handle (1)
- M. Liner (1)

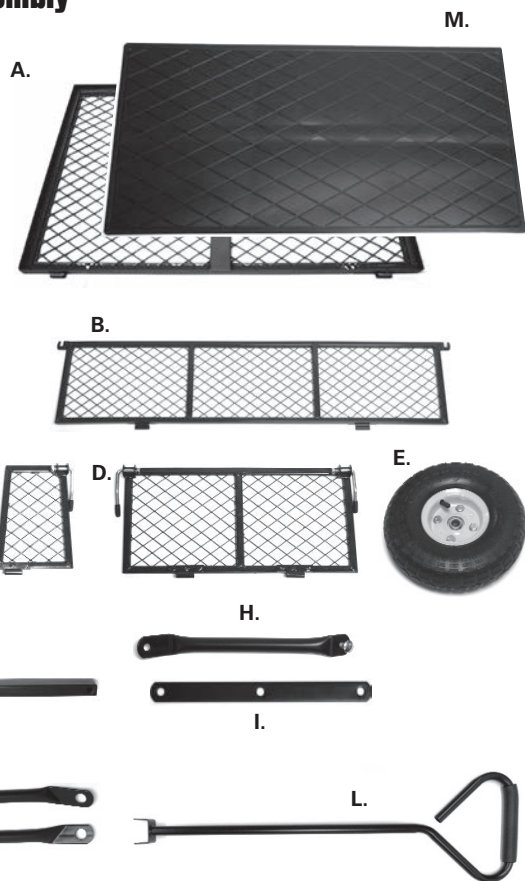

### Hardware List

- A. Fence Assembly Pins (8)
- B. M8x180 Carriage Bolt (1)
- C. M8 Washers (6)
- D. M8 Lock Nuts (6)
- E. M10 Washer (1)
- F. Cotter Pin (1)
- G. M8x17 Shoulder Bolts (2)
- H. M6 Washers (2)
- I. M6 Lock Nuts (2)
- J. M8x20 Carriage Bolts (4)
- K. Wheel Nylon Spacers (4)
- L. M12 Washers (4)
- M. M12 Lock Nuts (4)
- N. M8x60 Hex Bolt (1)

Images are not to scale

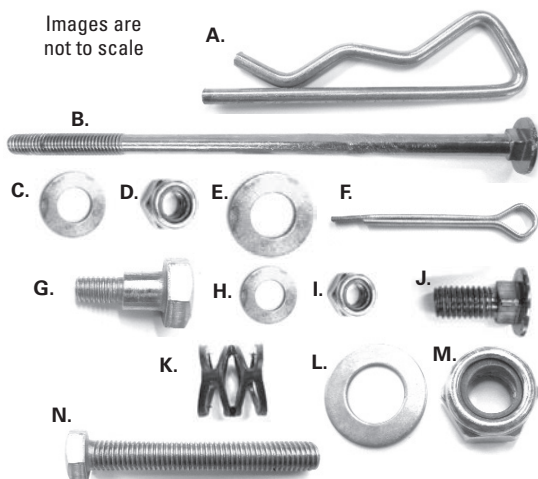

## Replacement Parts List

For replacement parts, please visit us online at [www.tricam.com](http://www.tricam.com) to complete the replacement parts submission form or call our customer service department at 1-800-867-6763, 9 a.m. - 4 p.m., CST, Monday - Friday.

### Parts List

- B. Side Panels (2)
- C. Front Panel (1)
- D. Back Panel (1)
- E. 10in (25.4cm) Wheels (4)
- F. Front Axle Sub-Assembly (1)
- G. Yoke (1)
- H. Front Strut (1)
- I. Front Axle Connection Bar (1)
- J. Rear Axle Sub-Assembly (1)
- K. Rear Struts (2)
- L. Handle (1)
- M. Liner
- N. Hardware Kit

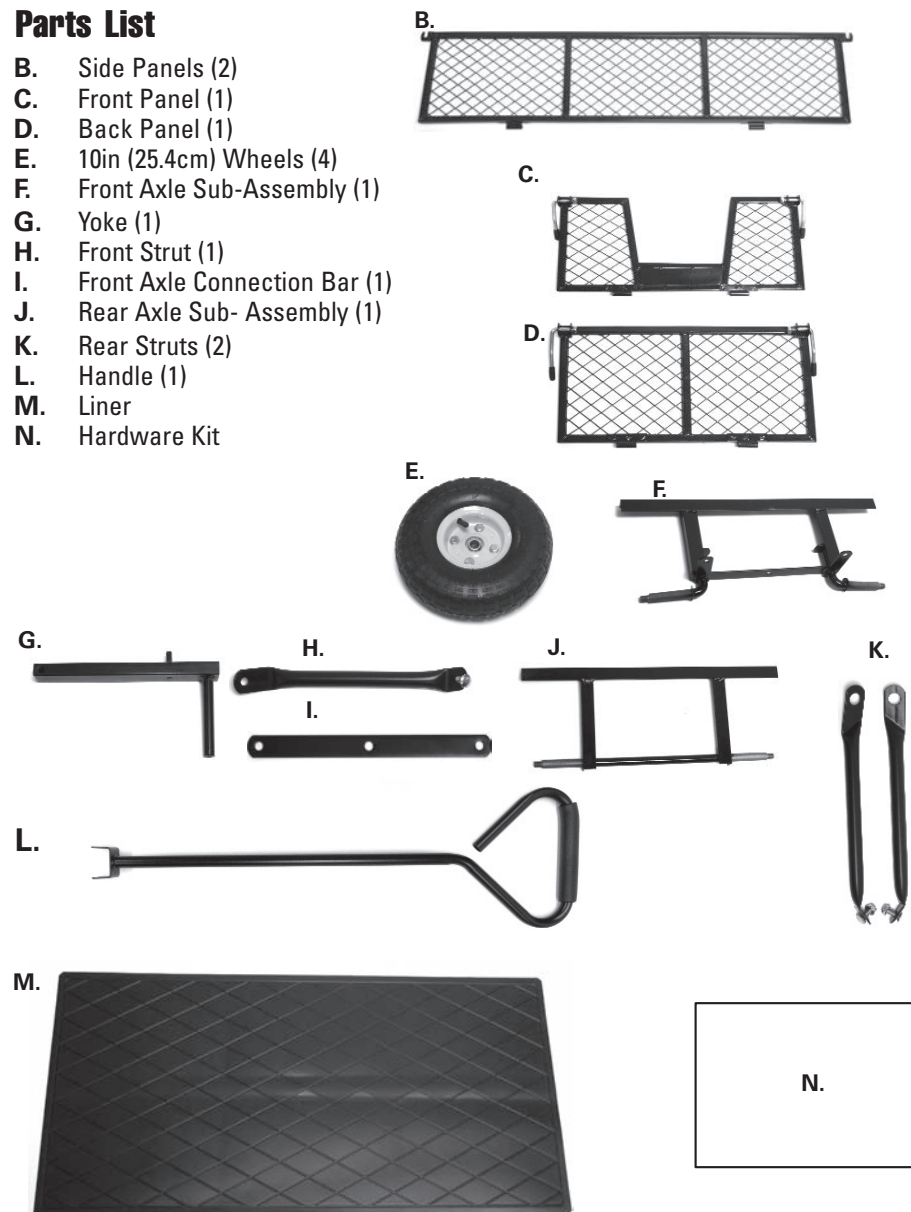

### Step 8

Attach the handle to the yoke using M8x180 hex bolt (1), M8 washer (1) and M8 lock nut (1). Tighten securely.



### Step 9

The lock handles are pre-assembled onto the panels. NOTE: Do not tighten the lock nuts on the lock handles until the end of this step. Attach the front, back, and side panels (2) onto the bed using the fence assembly pins. Latch the front and back panels to the side panels using the lock handles. Once all panels are locked together in the upright position, tighten all M8 lock nuts on the lock handles for smooth operation without being overly tight.



## Important Safety Instructions

1. **READ ALL INSTRUCTIONS CAREFULLY BEFORE USE.** If you do not understand these instructions, need clarification or further explanation, please call our toll free answer line for assistance at **1-800-867-6763**. Monday through Friday 9:00 a.m. until 4 :00 p.m. CST.
2. Do not exceed the overall maximum load capacity of 900 lbs (408 kg). The weight rating is based on an evenly distributed load.
3. Do not load items on the top edges of the panels. Remove panels before loading oversized items.
4. Do not allow children to use this cart without supervision. This cart is not a toy.
5. Do not use this cart to transport passengers.
6. This cart is not intended for highway use.
7. Do not exceed 5 mph.
8. If any parts become damaged, broken or misplaced, do not use the cart until replacement parts have been obtained.
9. Do not use the cart on surfaces or for transporting objects that can cause damage to the pneumatic tires or tubes. **Do not inflate the tires to more than 30 PSI (2.07 BAR).**
10. It is recommended that the cart be inspected for damage before each use.
11. **KEEP THESE INSTRUCTIONS FOR FURTHER REFERENCE.**

## Assembly Instructions

Your cart requires assembly. Account for all parts and hardware before beginning assembly. If any parts are missing, damaged or if you have questions or need additional instructions DO NOT RETURN THIS PRODUCT TO THE RETAILER, visit us online at [www.tricam.com](http://www.tricam.com) to complete the replacement parts submission form or call our customer service department at **1-800-867-6763**.

Tools required for assembly: pliers, adjustable wrenches and/or metric socket set

**NOTE: During each step of assembly, assemble all hardware and hand tighten. Once all the hardware is installed for that particular step, tighten all hardware.**

### Step 1

Turn the cart bed upside down. Use the cardboard from the carton to keep from scratching or damaging the finish.

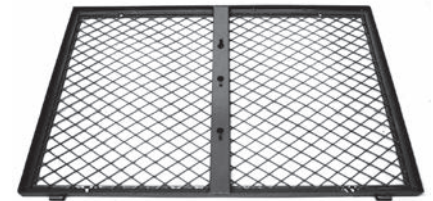

### Step 2

Attach the front strut and yoke to the front axle sub-assembly using M8x180 carriage bolt (1), M8 washer (1) and M8 lock nut (1). Tighten securely.

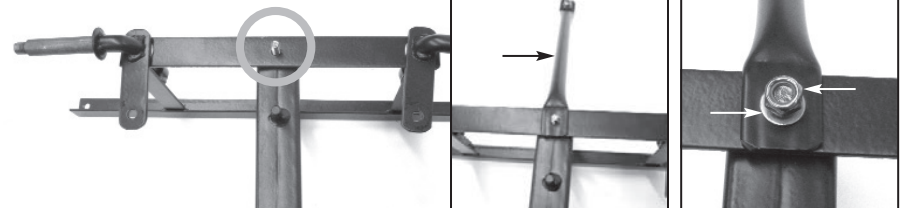

**CAUTION**

**DO NOT EXCEED MAXIMUM OVERALL LOAD CAPACITY 900 LBS (408 KG). PERSONS SHOULD NEVER RIDE IN THE UTILITY CART. WEIGHT RATING IS BASED ON AN EVENLY DISTRIBUTED LOAD.**

### Step 3

Attach the connection bar onto the front axle subassembly using M8x17 shoulder bolts (2), M6 washers (2), M6 lock nuts (2) M10 washer (1) and cotter pin (1).

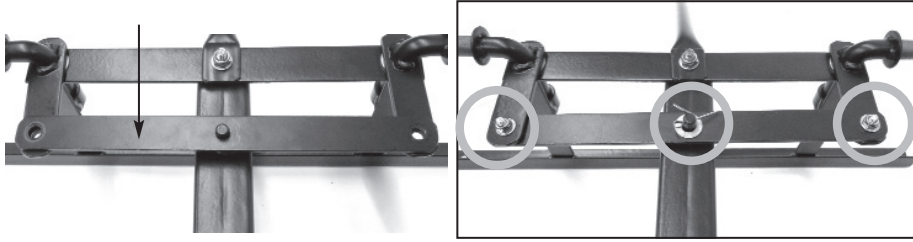

### Step 4

Attach the front axle assembly and front strut to the bed using M8x20 carriage bolts (2), M8 washers (2) and M8 lock nuts (2). **NOTE: the hardware to attach the front strut to the bed is pre-assembled to the strut.**

A. Place the front axle assembly and front strut onto the bed. Attach the front strut to the bed first. Place the M8x25 carriage bolt (pre-assembled to the strut) into the pre-punched hole on the bed and slide it into place. Lift up slightly on the strut and tighten bolt securely.



B. Next secure the front axle assembly to the bed using M8x20 carriage bolts (2), M8 washers (2) and M8 lock nuts (2). Tighten bolts securely.



### Step 5

Attach the rear axle assembly and rear struts onto the bed using M8x20 carriage bolts (2), M8 washers (2) and M8 lock nuts (2). **NOTE: the hardware to attach the rear struts to the bed is pre-assembled to each strut.**

A. Slide the rear struts onto each end of the rear axle assembly.



**Continued**

### Step 5 Continued

B. Place the rear axle assembly and rear struts onto the bed. Attach the rear struts to the bed first. Place the M8x25 carriage bolts (pre-assembled to the strut) into the pre-punched holes on the bed and slide them into place. Lift up slightly on each strut and tighten bolts securely.



C. Next secure the rear axle assembly to the bed using M8x20 carriage bolts (2), M8 washers (2) and M8 lock nuts (2). Tighten bolts securely.

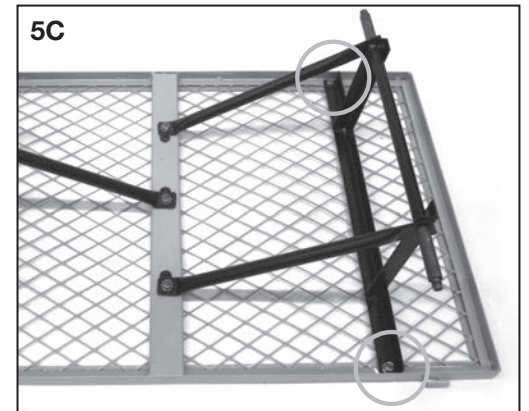

### Step 6

Attach the wheels by first placing the nylon wheel spacers (4) onto the front and rear axles.



### Step 7

Place the wheels onto each axle (valve stems facing out) using M12 wheel washers (4) and M12 lock nuts (4). Tighten all nuts securely. Turn the cart upright on all 4 wheels.

