

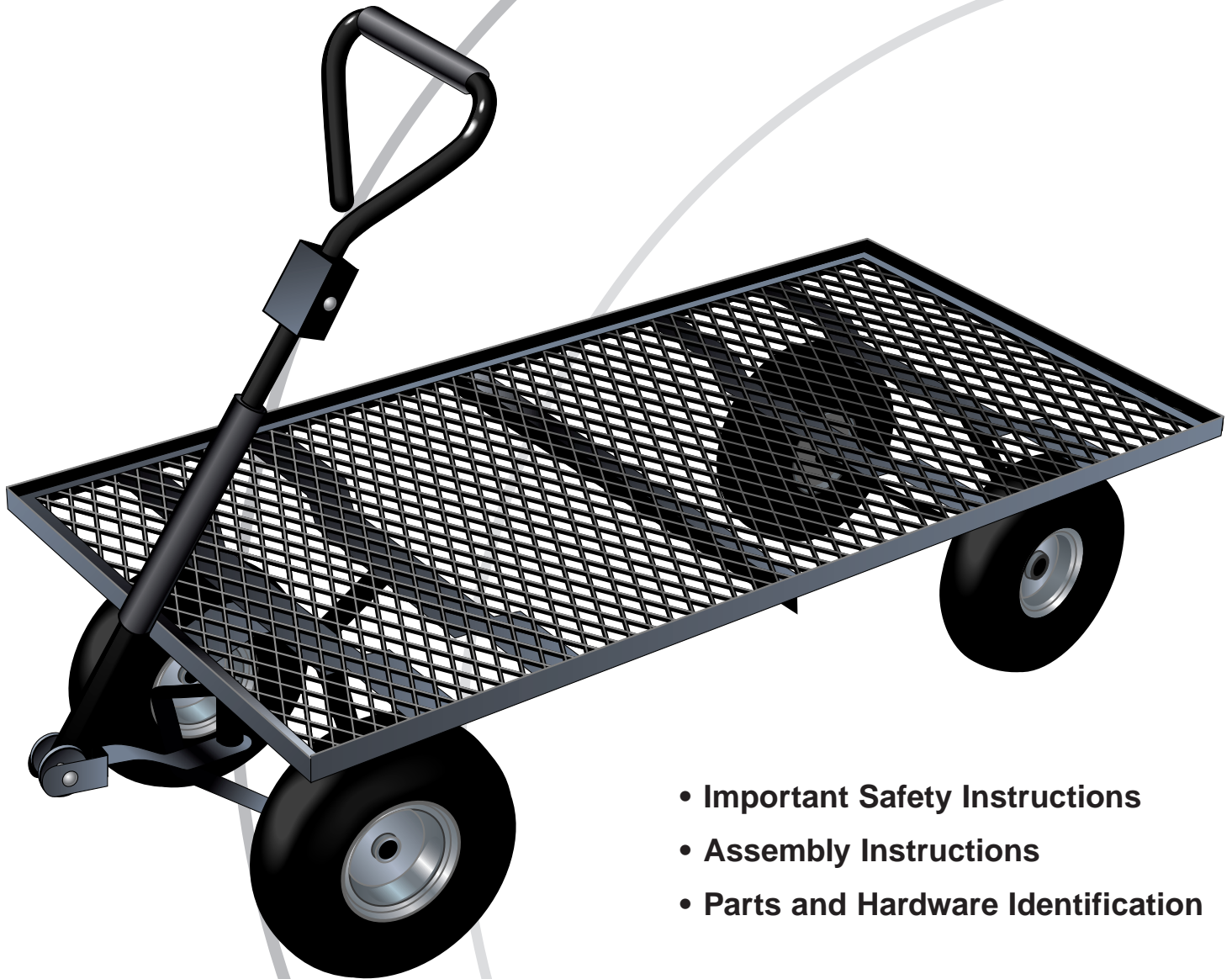

OWNER'S MANUAL

Model TC1807DW



- Important Safety Instructions
- Assembly Instructions
- Parts and Hardware Identification

Flatbed Cart

CAUTION:

Read, understand and follow ALL instructions before using this product

MCM International
7677 Equitable Drive
Minneapolis, MN 55344
800-304-1316

IMPORTANT SAFETY INSTRUCTIONS

1. **READ ALL INSTRUCTIONS CAREFULLY BEFORE USE.** If you do not understand these instructions, need clarification or further explanation, please call our toll free answer line for assistance at **1-800-304-1316** Monday through Friday 8:00 a.m. until 5:00 p.m. CST.
2. Do not load Flatbed Cart with more than 1000 lbs. (450 kg)
3. Do not allow children to use the cart unsupervised. This Flatbed Cart is not a toy.
4. Always distribute payload evenly over surface of bed.
5. If any parts become damaged, broken or misplaced do not use the wagon until replacement parts can be obtained.
6. Do not operate or use on objects that can cause damage to the pneumatic tires or tubes.
Do not inflate tires more than 30 psi.
7. **SAVE THESE INSTRUCTIONS.**

ASSEMBLY INSTRUCTIONS

Your Flatbed Cart requires assembly. Account for all parts and hardware before beginning assembly. If any parts are missing, damaged or if you have questions or need additional instructions **DO NOT RETURN THIS PRODUCT TO THE RETAILER**, call the manufacturer at **1-800-304-1316**.

Tools required for assembly: Medium size slot screwdriver, 6, 8, and 12mm open end wrench and /or two medium adjustable wrenches.

Refer to the exploded drawing and the parts list on the following pages during assembly.

- STEP 1** Turn the cart BED upside down. Use the cardboard from the carton to keep from scratching or damaging the finish
- STEP 2** Assemble the REAR SUPPORT ASSEMBLY to the bed using 6 - 8 x 20mm Carriage Support Bolts and 6 - 8mm nuts. Attach the Rear Axle Support to the back of the bed and then attach the left and right Support Braces. Tighten all nuts securely.
- STEP 3** **There are four shoulder bolts - three short and one long. Be sure to use the long shoulder bolt (8 x 17mm) in the front center location of the steering mechanism.** Assemble the FRONT SUPPORT ASSEMBLY completely before attaching the completed assembly to the Bed.
- A. Attach the Steering Link Connector to the two axle guides using 2 - 8 x 15mm Steering Assembly Shoulder Bolts (short), 6mm Washers and 6mm Nuts. **NOTE:** Place the Steering Link Connector on top of the axle guides.
 - B. Place the Yoke into position on the Front Axle Support and secure to the Steering Link Connector using 1 - 8 x 15mm Steering Assembly Shoulder Bolt (short), 6mm Washer and 6mm Nut.
 - C. Attach the Center Front Axle brace to the Assembly as shown. Use 1 - 8 x 17mm Steering Assembly Shoulder Bolt (long), 6mm Washer and 6mm Nut.
 - D. Assemble the completed Front Support Assemble to the Bed using 4-Carriage Support Bolts, Nuts and Washers.
- STEP 4** Install the WHEELS in the following order.
- A. Place the Wheel Spacer bushing onto the axle.
 - B. Place the Wheel onto the axle with the valve stem facing out.
 - C. Use the 12mm washer and then the 12mm Nut to secure the wheel. Tighten Securely.
- STEP 5** Turn the cart upright onto its wheels. Attach the Tractor Pull Handle Yoke Washers and the Plastic Coupling using the 8 x 60mm pull handle bolt, 8mm washer and nut.

PARTS AND HARDWARE IDENTIFICATION

MAIN FRAME PARTS

- 1 Bed - (1)
- 2 10" x 3.5" Wheels - (4)

REAR SUPPORT ASSEMBLY

- 3 Rear Axle Support - (1)
- 4 Left Rear Axle Brace - (1)
- 5 Right Rear Axle Brace - (1)

FRONT SUPPORT ASSEMBLY

- 6 Front Axle Support - (1)
- 7 Center Front Axle Brace - (1)
- 8 Yoke - (1)
- 9 Steering Link Connector - (1)
- 10 Plastic Coupling - (1)
- 11 Pull Handle - (1)
- 12 Tractor Pull Handle - (1)

ASSEMBLY HARDWARE

- 13 Handle Clevis Pin - (1)
- 14 Clevis Pin - (1)
- 15 Washer 8mm - (1)
- 16 Nuts w/Lock Inserts 8mm - (11)
- 17 Wheel Spacer Bushings - (4)
- 18 Wheel Nuts 12mm - (4)
- 19 Wheel Lock Washers 12mm - (4)
- 20 Carriage Support Bolts 8 x 20mm - (10)
use with #16
- 21 Pull Handle Bolt 8 x 60mm - (1)
use with #15 & #16
- 22 Short Steering Assembly Shoulder Bolt
8 x 15mm - (3) use with #25 & #26
- 23 Long Steering Assembly Shoulder Bolt
8 x 17mm - (1) use with #25 & #26
- 24 Yoke Washers 8 x 25mm OD- (2)
- 25 Washers 6mm - (4)
- 26 Nuts w/Lock Inserts 6mm - (4)

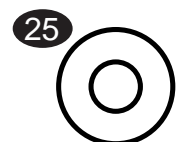
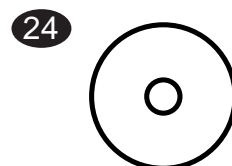
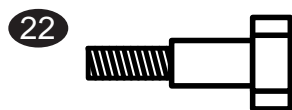
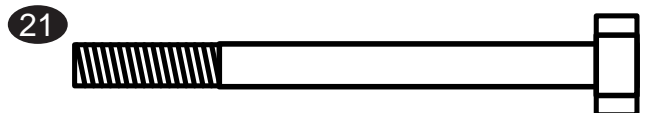
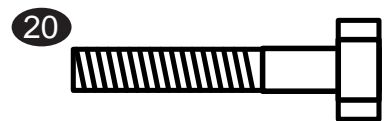
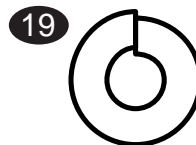
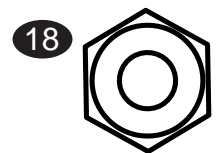
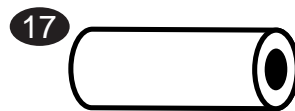
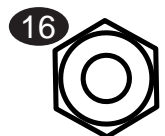
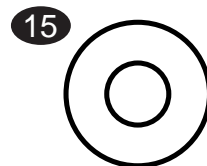
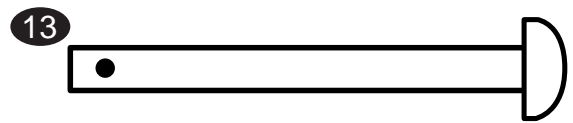

EXPLODED DRAWING FOR ASSEMBLY

