

6

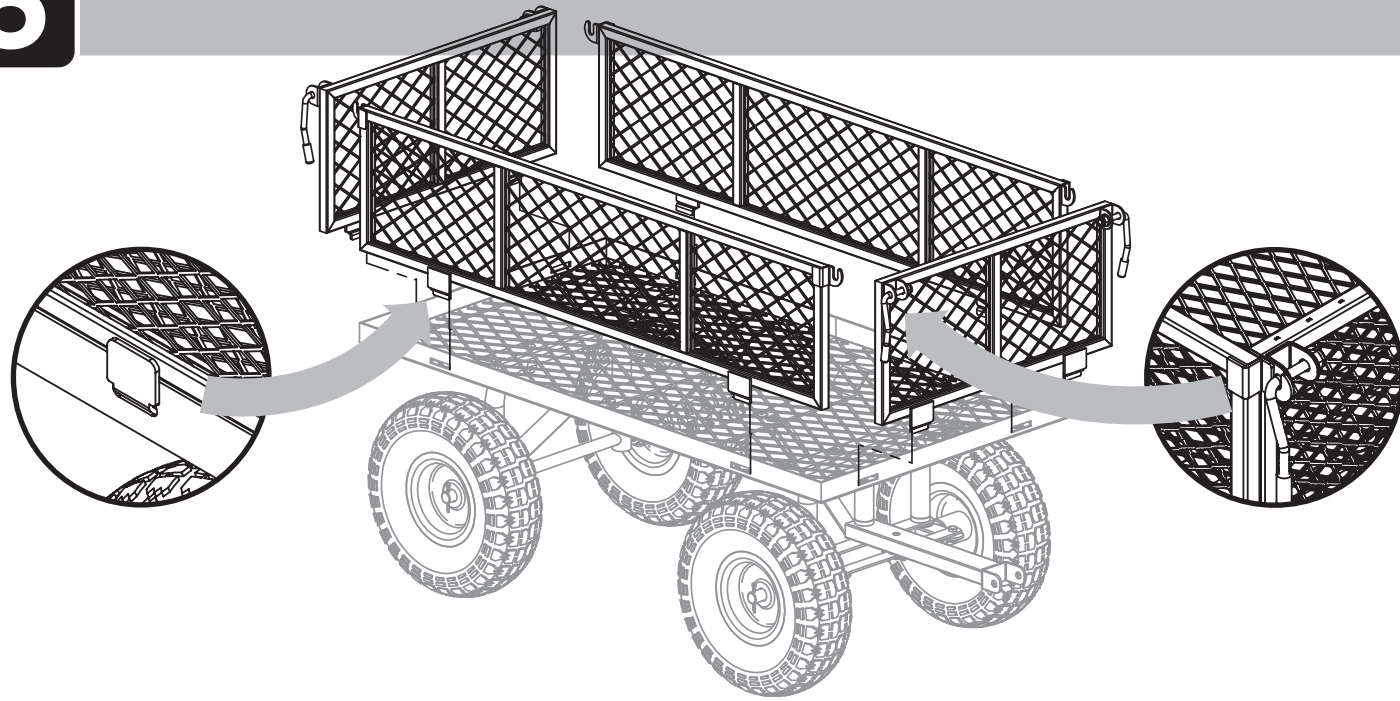

QUESTIONS, PROBLEMS, OR MISSING PARTS?

If any parts are missing, damaged, or if you have any questions or need additional instructions, **DO NOT RETURN THIS PRODUCT TO THE RETAILER**, visit us at www.tricam.com to complete the replacement parts submission form or call our customer service department at 1-800-867-6763, 9 a.m. - 4 p.m., CST, Monday-Friday.

¿PREGUNTAS, PROBLEMAS O PIEZAS FALTANTES?

Si falta alguna pieza o si tienes preguntas o necesitas instrucciones adicionales, **NO DEVUELVAS ESTE PRODUCTO AL MINORISTA**, visítanos en Internet en www.tricam.com para llenar el formulario de piezas de repuesto o llama a nuestro departamento del servicio del cliente al 1-800-867-6763, 9 a.m. a 4 p.m., Hora Estándar del Centro, de Lunes a Viernes.

IMPORTANT SAFETY INSTRUCTIONS

1. READ ALL INSTRUCTIONS CAREFULLY BEFORE USE.
2. Do not exceed the overall maximum load capacity of 400 lbs. (181 kg). The weight rating is based on an evenly distributed load.
3. Do not load items on the top edges of the panels. Remove panels before loading oversized items.
4. Do not allow children to use this cart without supervision. This cart is not a toy.
5. Do not use this cart to transport passengers.
6. This cart is not intended for highway use.
7. Do not exceed 5 mph.
8. If any parts become damaged, broken, or misplaced, do not use the cart until replacement parts have been obtained.
9. Do not use the cart on surfaces or for transporting objects that can cause damage to the pneumatic tires or tubes. **Do not inflate the tires TO MORE THAN 30 psi (2.07 BAR).**
10. It is recommended that the cart be inspected for damage before each use.
11. KEEP THESE INSTRUCTIONS FOR FURTHER REFERENCES.

INSTRUCCIONES IMPORTANTES DE SEGURIDAD

1. LEE CON CUIDADO TODAS LAS INSTRUCCIONES ANTES DE USAR.
2. No sobrepases la capacidad total de carga máxima de 400 lbs. (181 kg). La capacidad de peso nominal está basada en una carga distribuida de manera uniforme.
3. No cargues artículos en los bordes superiores de los paneles. Quitá los paneles antes de cargar artículos grandes.
4. No permitas que los niños usen este carrito sin supervisión. Este carrito no es un juguete.
5. No lo uses para transportar pasajeros.
6. Este carrito no está diseñado para usar en autopistas.
7. No sobrepases las 5 mph.
8. Si alguna de las piezas se daña, rompe o pierde, no uses el carrito hasta obtener la pieza de repuesto.
9. No usar el carrito sobre superficies o para transportar objetos que puedan causar daños a los neumáticos o las cámaras. **No infles los neumáticos a más de 30 PSI (2,07 BAR).**
10. Se recomienda revisar el carrito antes de cada uso para detectar cualquier daño.
11. GUARDA ESTAS INSTRUCCIONES PARA FUTURAS CONSULTAS.

Tricam Industries Inc.
7677 Equitable Drive
Eden Prairie, MN 55344
1-800-867-6763 • www.tricam.com

181174A



MODEL# CT400

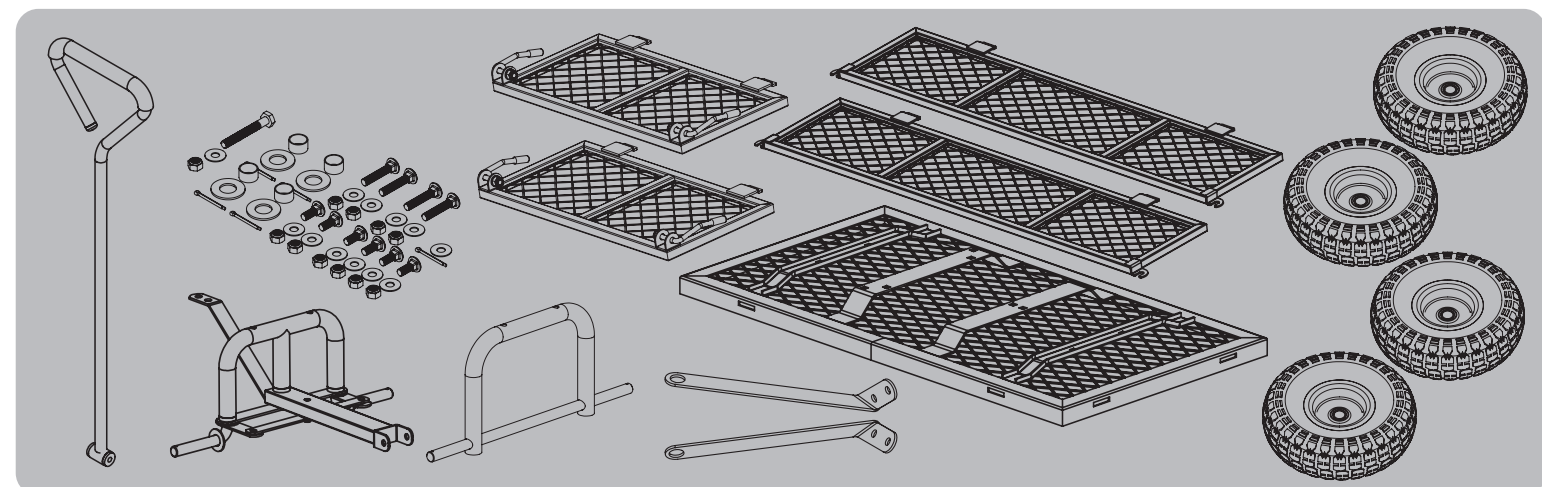

HARDWARE • HERRAJES

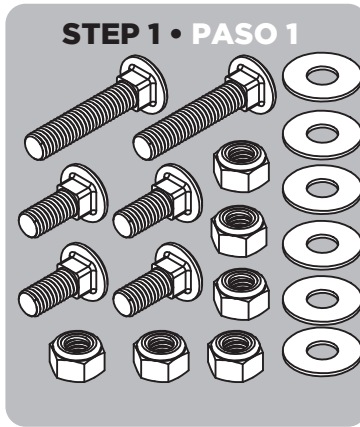
STEP 1 • PASO 1

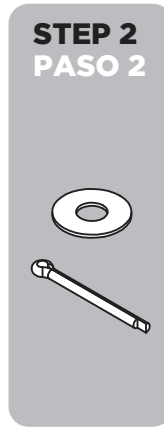
STEP 2 • PASO 2

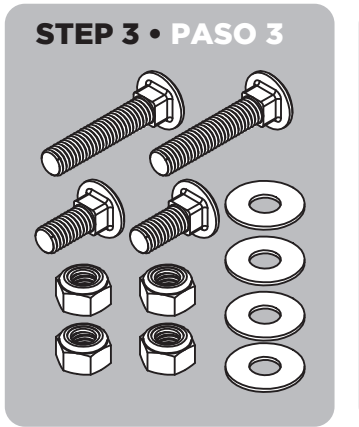
STEP 3 • PASO 3

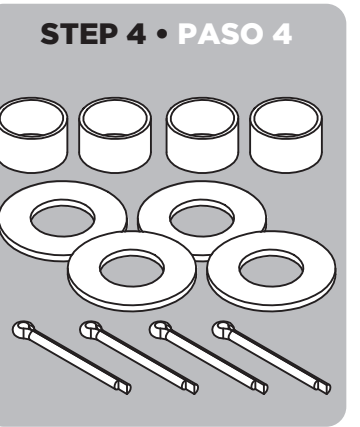
STEP 4 • PASO 4

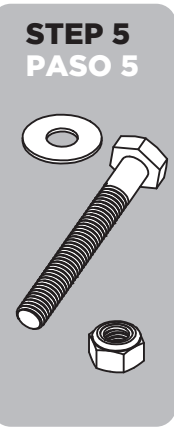
STEP 5 • PASO 5

TOOLS REQUIRED • HERRAMIENTAS NECESARIAS



ASSEMBLY INSTRUCTIONS • INSTRUCCIONES DE ENSAMBLAJE

1  **2** 

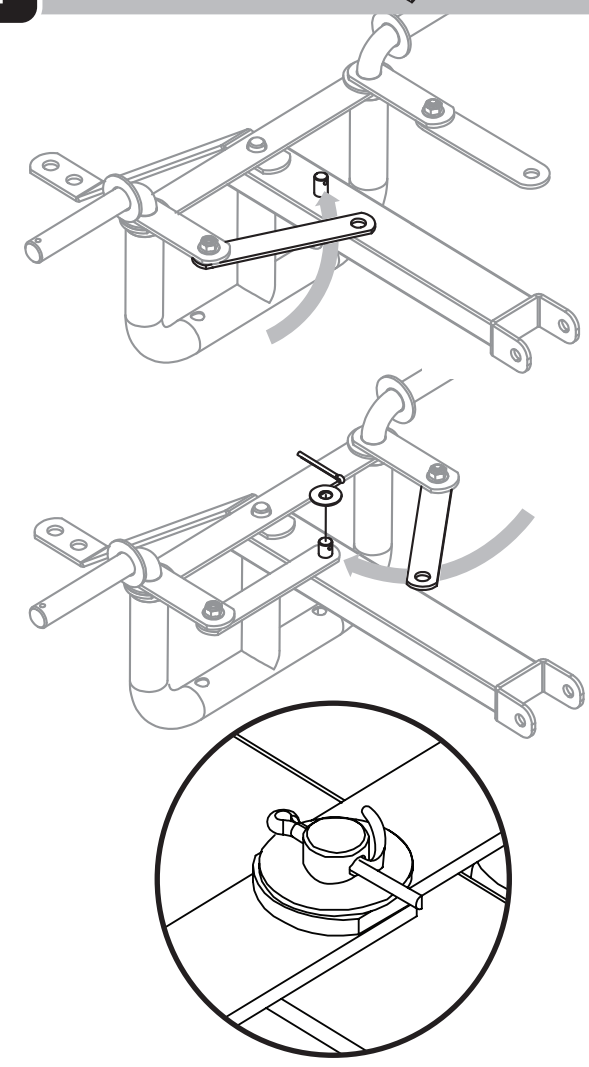
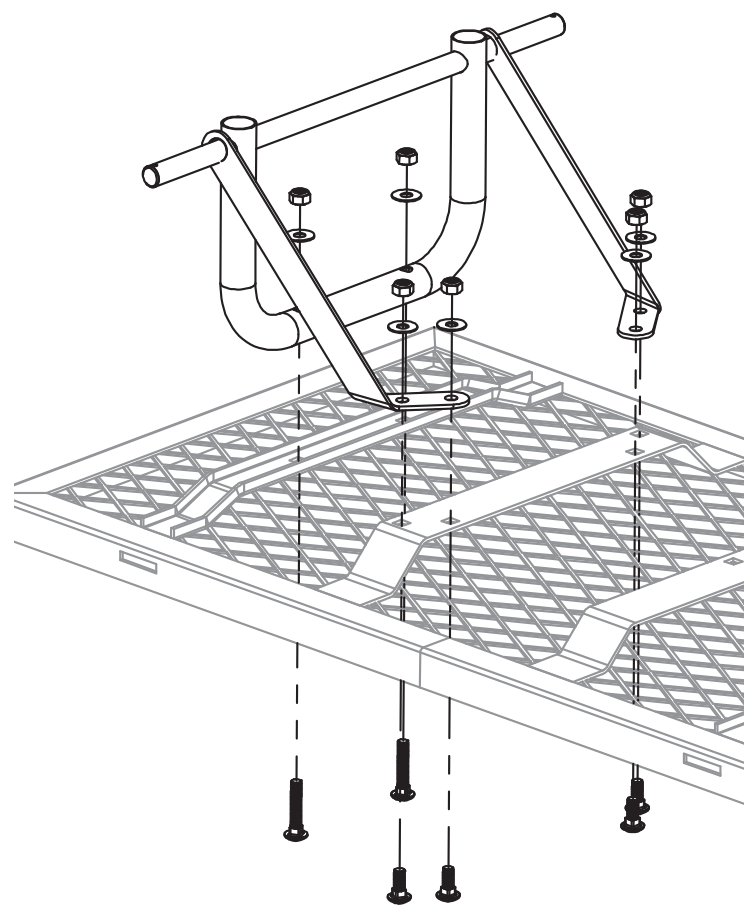

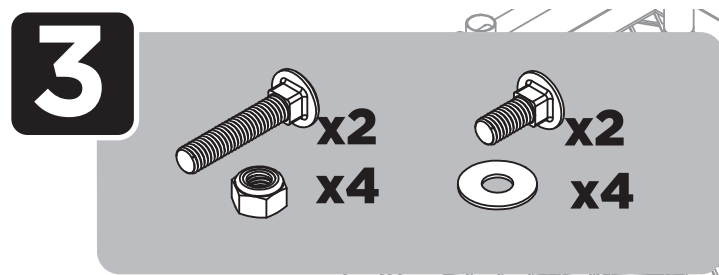
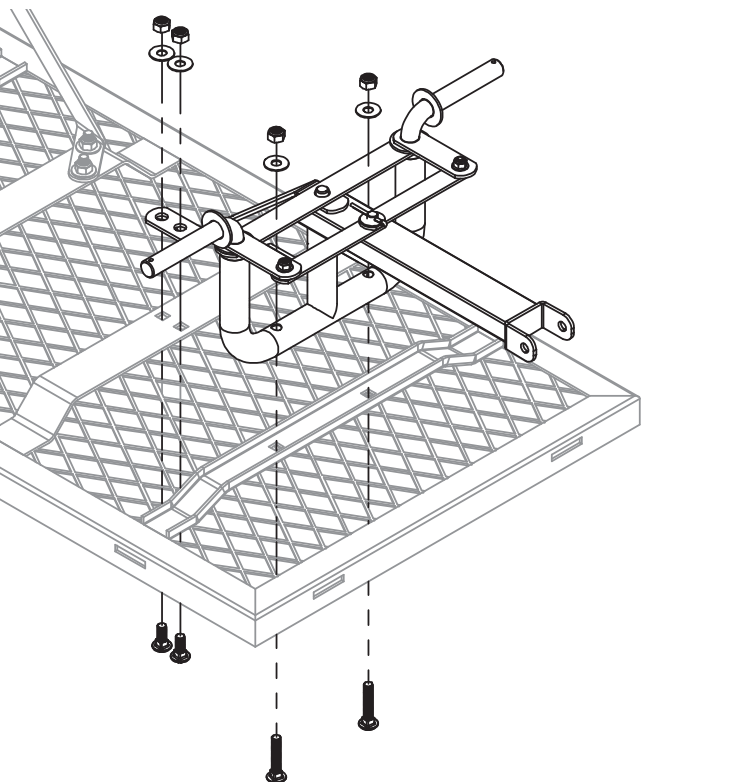
3  

4 

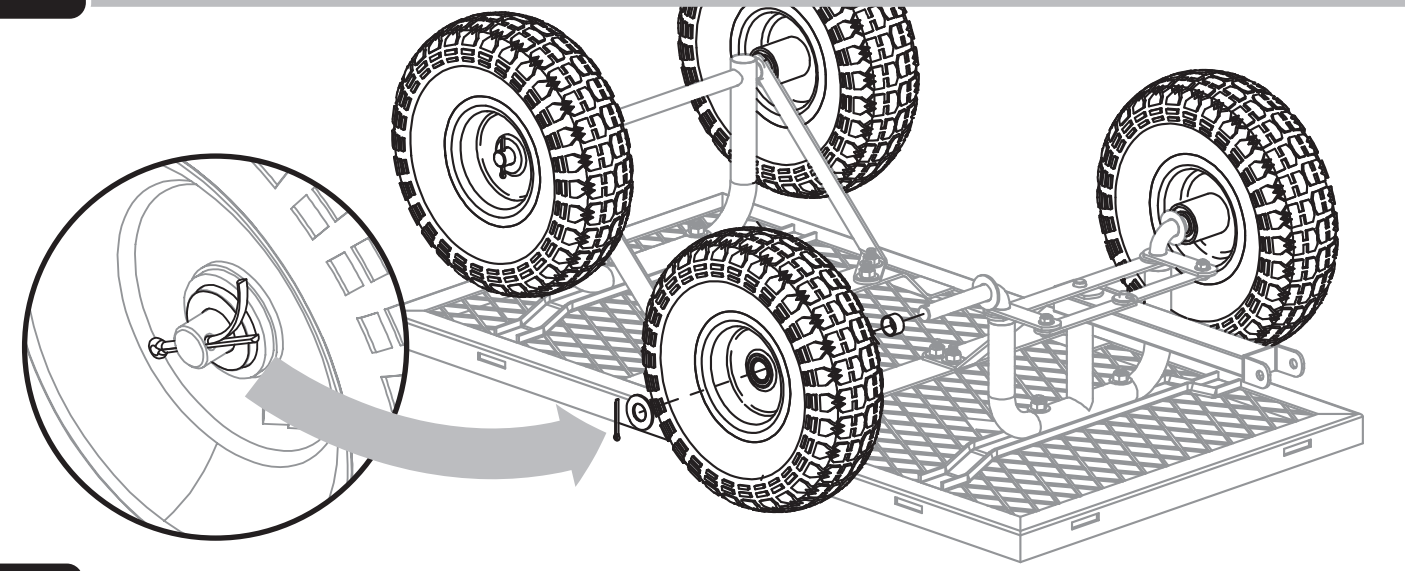

5 