

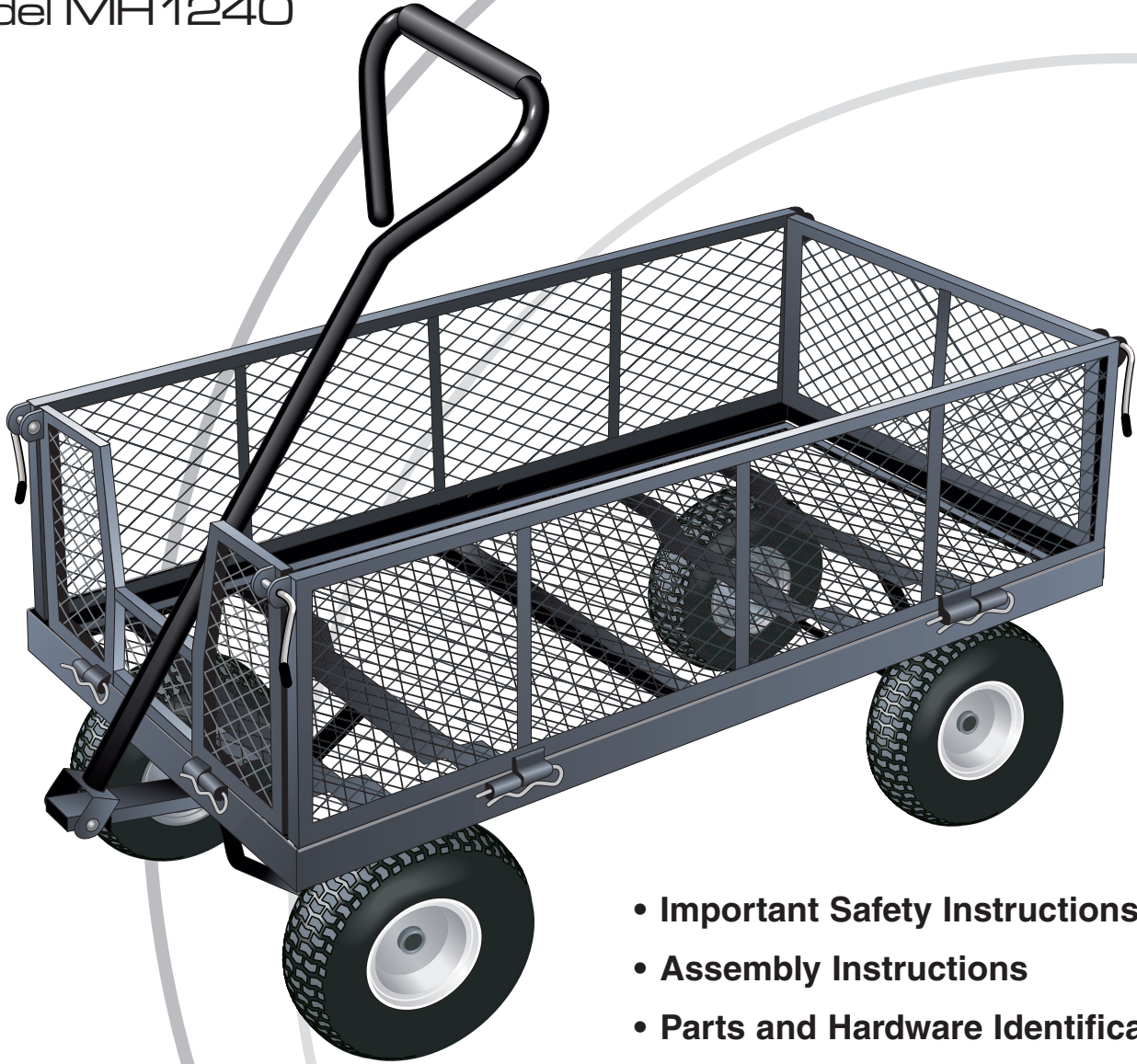

OWNER'S MANUAL

Model MH1240



- Important Safety Instructions
- Assembly Instructions
- Parts and Hardware Identification

Utility Wagon

With Removeable Folding Sides

CAUTION:

Read, understand and follow ALL instructions before using this product

RMM Corporation
7677 Equitable Drive
Minneapolis, MN 55344
800-304-1316
www.black-cat-products.com

/// WARNING:

**NOT FOR RECREATIONAL USE -
PERSONS SHOULD NEVER RIDE
IN THE WAGON**

IMPORTANT SAFETY INSTRUCTIONS

1. **READ ALL INSTRUCTIONS CAREFULLY BEFORE USE.** If you do not understand these instructions, need clarification or further explanation, please call our toll free answer line for assistance at **1-800-304-1316** Monday through Friday 8:00 a.m. until 5:00 p.m. CST.
2. Do not load wagon with more than 800 lbs.
3. Do not allow children to use the wagon unsupervised. This Wagon is not a toy.
4. Always distribute payload evenly over surface of bed.
5. Do not load any items on top of the fence. Lower fence when objects are to be loaded onto the wagon.
6. If any parts become damaged, broken or misplaced do not use the wagon until replacement parts can be obtained.
7. Do not operate or use on objects that can cause damage to the pneumatic tires or tubes.
Do not inflate tires more than 32 psi.
8. **SAVE THESE INSTRUCTIONS.**

ASSEMBLY INSTRUCTIONS

Your Wagon requires assembly. Account for all parts and hardware before beginning assembly. If any parts are missing, damaged or if you have questions or need additional instructions **DO NOT RETURN THIS PRODUCT TO THE RETAILER**, call the manufacturer at **1-800-304-1316**.

Tools required for assembly: Medium size slot screwdriver, 6, 8, and 12mm open end wrench and /or two medium adjustable wrenches.

Refer to the exploded drawing and the parts list on the following pages during assembly.

STEP 1 Assemble the REAR SUPPORT ASSEMBLY to the bed using (4) 8 x 20mm Carriage Support Bolts, (2) 8 x 45mm Carriage Support Bolts, and 6 - 8mm washers and lock nuts. Attach the Rear Axle Support to the back of the bed using the (2) 8 x 45mm Carriage Support Bolts and then attach the Left and Right Rear Axle Braces using the (4) 8 x 20mm Carriage Support Bolts. Tighten all nuts securely.

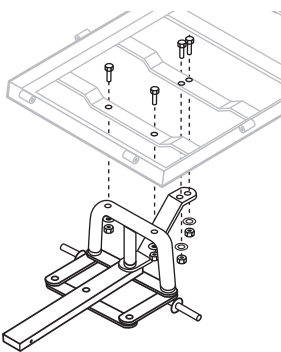
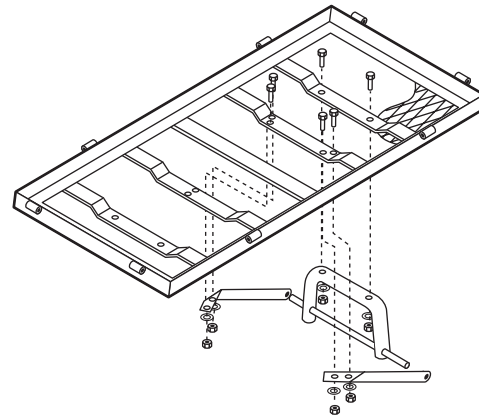

STEP 2 The front support assembly is mostly pre-assembled at the factory. Please make sure all bolts and nuts assembled at the factory are tight.

- A. Attach the Front Axle Support to the bed of the wagon using (2) 8 x 45mm Carriage Support Bolts, 8mm washers and lock nuts.
- B. Secure the Center Front Axle Brace to the bed of the wagon using (2) 8 x 20mm Carriage Support Bolts, 8mm washers and lock nuts.

STEP 3 Install the WHEELS in the following order.

- A. Place the Wheel Spacer bushings onto the axles.
- B. Place the Wheels onto the axles with the valve stem facing out.
- C. Use the 12mm washers and the cotter pins to secure the wheels.

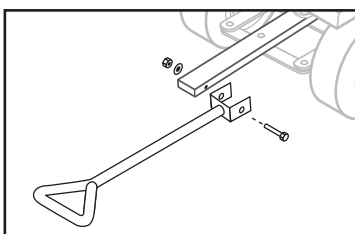
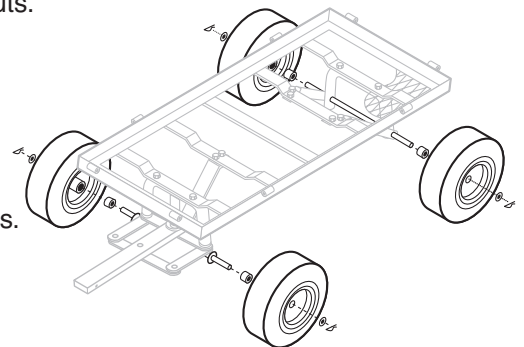

STEP 4 Attach the Pull Handle to the Front Axle Support using the 8 x 60mm Pull Handle bolt, 8mm washer and lock nut.

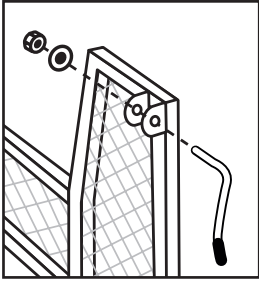

STEP 5 Attach the Lock Handles onto the Front and Back Panels using 8mm washers and lock nuts. **NOTE: Do not fully tighten the lock nuts. These are to be adjusted after finishing the panel assembly.**

STEP 6 Attach the Front, Back, and Side Panels using the Pins.

NOTE: Latch the Panels in the upright position using the Lock Handles. Tighten the lock nuts on the Lock Handles to allow for smooth operation without being overly tight.

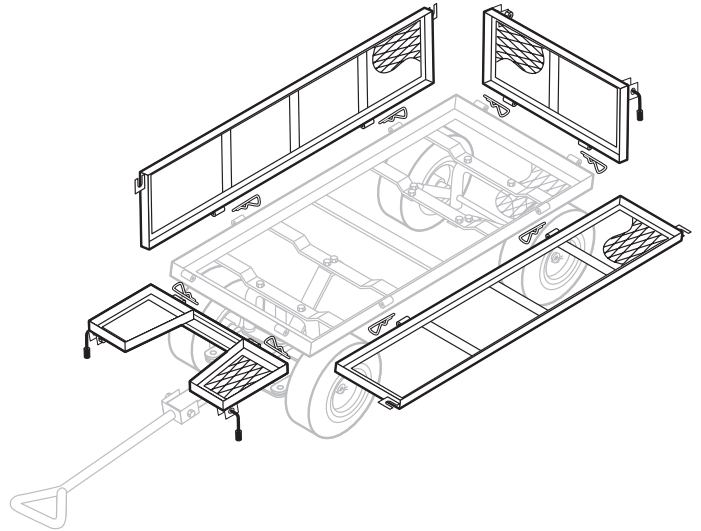

PARTS AND HARDWARE IDENTIFICATION

MAIN FRAME PARTS

- 1 Bed - (1)
- 2 Sides Panels - (2)
- 3 Front Panel - (1)
- 4 Back Panel - (1)
- 5 10" Wheels - (4)

REAR SUPPORT ASSEMBLY

- 6 Rear Axle Support - (1)
- 7 Left Rear Axle Brace - (1)
- 8 Right Rear Axle Brace - (1)

FRONT SUPPORT ASSEMBLY

- 9 Front Axle Support - (1)
- 10 Center Front Axle Brace - (1)
- 11 Pull Handle - (1)

ASSEMBLY HARDWARE

- 12 Fence Assembly Pins - (8)
- 13 Lock Handles 8mm - (4)
- 14 Washers 8mm - (15)
- 15 Lock Nuts 8mm - (15)
- 16 Wheel Spacer Bushings - (4)
- 17 Wheel Cotter Pins (4)
- 18 Wheel Washer 12mm
- 19 Carriage Support Bolts 8 x 20mm - (6)
- 20 Carriage Support Bolts 8 x 45mm - (4)
- 21 Pull Handle Bolt 8 x 60mm - (1)

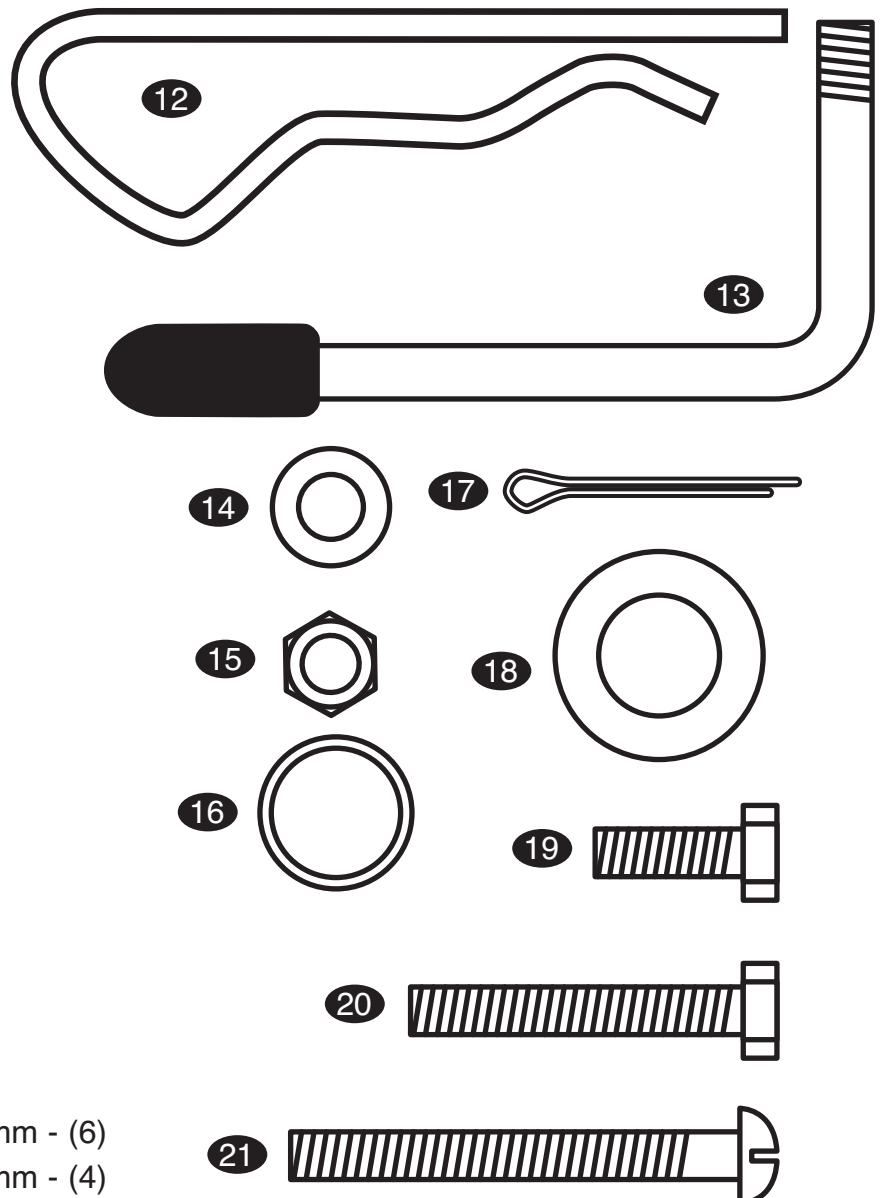

EXPLODED DRAWING FOR ASSEMBLY

